Biomolecules
Multiple Choice Questions (Type-I)

1. **Glycogen is a branched chain polymer of α -D-glucose units in which chain is formed by C₁—C₄ glycosidic linkage whereas branching occurs by the formation of C₁-C₆ glycosidic linkage. Structure of glycogen is similar to _____.**

- (i) Amylose
- (ii) Amylopectin
- (iii) Cellulose
- (iv) Glucose

Ans. (ii)

Explanation: Polysaccharides contain a large number of monosaccharide units joined together by glycosidic linkages. These are the most commonly encountered carbohydrates in nature. Amylopectin is insoluble in water and constitutes about 80-85% of starch. It is a branched chain polymer of alpha-D-glucose units in which chain is formed by C₁-C₄ glycosidic linkage whereas branching occurs by C₁-C₆ glycosidic linkage.

2. **Which of the following polymer is stored in the liver of animals?**

- (i) Amylose
- (ii) Cellulose
- (iii) Amylopectin
- (iv) Glycogen

Ans. (iv)

Explanation: The carbohydrates are stored in animal body as glycogen. It is also known as animal starch because its structure is similar to amylopectin and is rather more highly branched. It is present in liver, muscles and brain.

3. **Sucrose (cane sugar) is a disaccharide. One molecule of sucrose on hydrolysis gives _____.**

- (i) 2 molecules of glucose
- (ii) 2 molecules of glucose + 1 molecule of fructose
- (iii) 1 molecule of glucose + 1 molecule of fructose
- (iv) 2 molecules of fructose

Ans. (iii)

Explanation: One of the common disaccharides is sucrose which on hydrolysis gives equimolar mixture of D-(+)-glucose and D-(-) fructose.

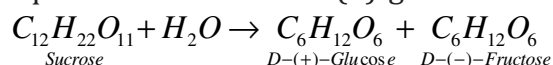

4. **Which of the following pairs represents anomers?**

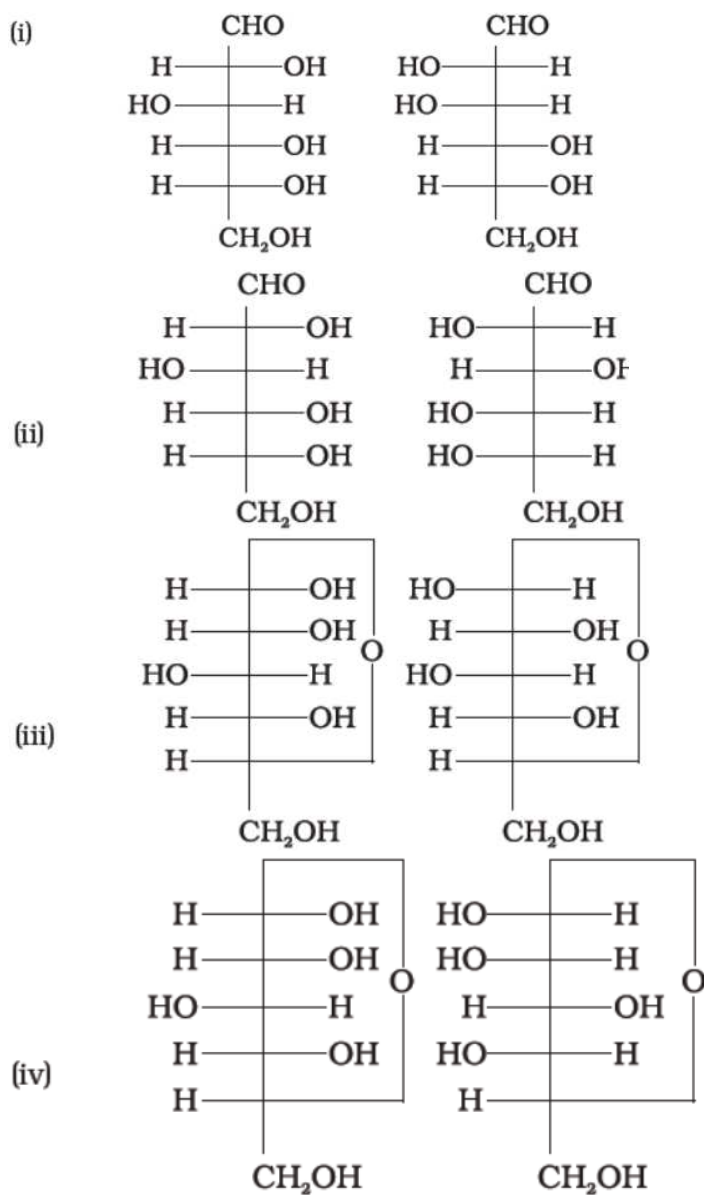

Ans. (iii)

Explanation: The two cyclic hemiacetal forms of glucose differ only in the configuration of the hydroxyl group at C1, called anomeric carbon (the aldehyde carbon before cyclisation). Such isomers, i.e., alpha-form and beta-form, are called anomers.

5. Proteins are found to have two different types of secondary structures viz. α -helix and β -pleated sheet structure. α -helix structure of protein is stabilised by:

- (i) Peptide bonds
- (ii) van der Waals forces
- (iii) Hydrogen bonds
- (iv) Dipole-dipole interactions

Ans. (iii)

Explanation: α -helix and β -pleated sheet structure: These structures arise due to the regular folding of the backbone of the polypeptide chain due to hydrogen bonding between $>C=O$ and $-NH-$ group of the peptide bond.

α -Helix is one of the most common ways in which a polypeptide chain forms all possible hydrogen bond by twisting into a right-handed screw (helix) with the $-NH$ group of each amino acid **residue hydrogen bonded** to the $>C=O$ of an adjacent turn of the helix.

6. In disaccharides, if the reducing groups of monosaccharides i.e. aldehydic or ketonic groups are bonded, these are non-reducing sugars. Which of the following disaccharide is a non-reducing sugar?

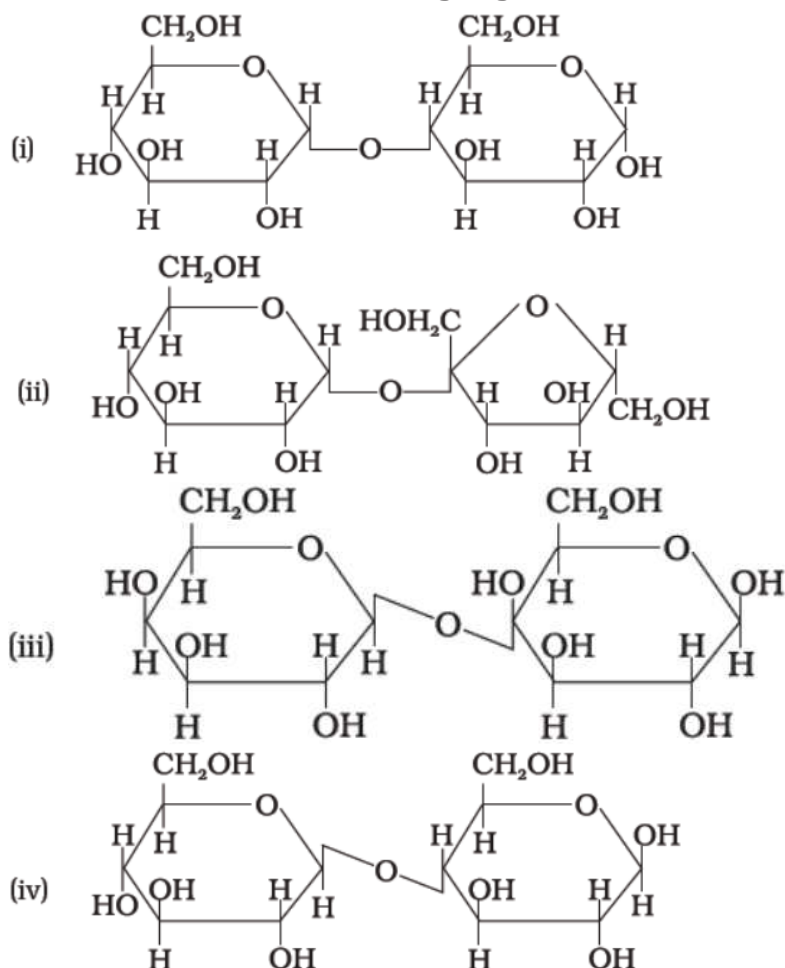

Ans. (ii)

Explanation: One of the common disaccharides is sucrose which on hydrolysis gives equimolar mixture of D-(+)-glucose and D-(-) fructose. These two monosaccharides are held together by a glycosidic linkage between C1 of α -glucose and C2 of beta-fructose. Since the reducing groups of glucose and fructose are involved in glycosidic bond formation, sucrose is a non-reducing sugar.

7. Which of the following acids is a vitamin?
-

-
- (i) Aspartic acid
 - (ii) Ascorbic acid
 - (iii) Adipic acid
 - (iv) Saccharic acid

Ans. (ii)

Explanation: Vitamin C is also known as Ascorbic acid.

8. **Dinucleotide is obtained by joining two nucleotides together by phosphodiester linkage. Between which carbon atoms of pentose sugars of nucleotides are these linkages present?**

- (i) 5' and 3'
- (ii) 1' and 5'
- (iii) 5' and 5'
- (iv) 3' and 3'

Ans. (i)

Explanation: Nucleotides are joined together by phosphodiester linkage between 5' and 3' carbon atoms of the pentose sugar.

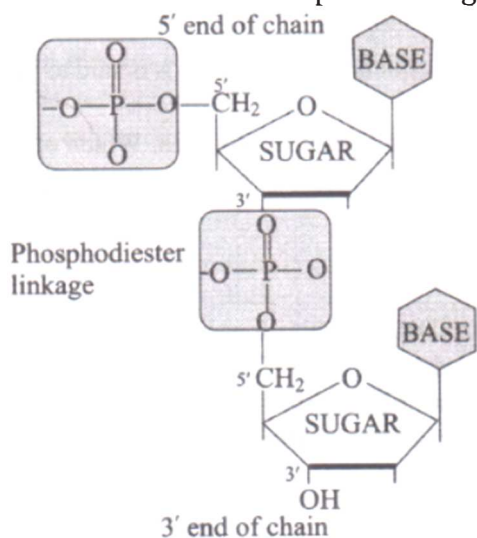

9. **Nucleic acids are the polymers of _____.**

- (i) Nucleosides
- (ii) Nucleotides
- (iii) Bases
- (iv) Sugars

Ans. (ii)

Explanation: Nucleic acids are long chain polymers of nucleotides, so they are also called polynucleotides.

10. **Which of the following statements is not true about glucose?**

- (i) It is an aldohexose.
 - (ii) On heating with HI it forms *n*-hexane.
-

- (iii) It is present in furanose form.
(iv) It does not give 2,4-DNP test.

Ans. **(iii)**

Explanation: Fructose is present in furanose form.

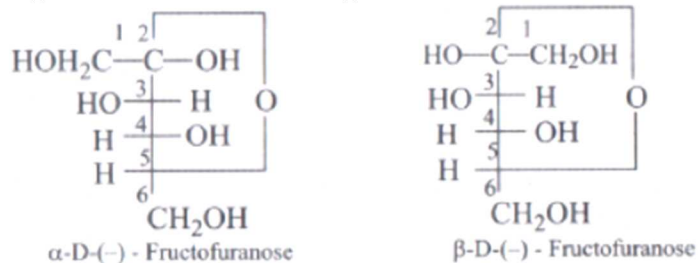

11. **Each polypeptide in a protein has amino acids linked with each other in a specific sequence. This sequence of amino acids is said to be _____.**

- (i) primary structure of proteins.
(ii) secondary structure of proteins.
(iii) tertiary structure of proteins.
(iv) quaternary structure of proteins.

Ans. **(i)**

Explanation: Sequence of amino acids is said to be primary structure of proteins.

12. **DNA and RNA contain four bases each. Which of the following bases is not present in RNA?**

- (i) Adenine
(ii) Uracil
(iii) Thymine
(iv) Cytosine

Ans. **(iii)**

Explanation: DNA contains four bases viz. adenine (A), guanine (G), cytosine (C) and thymine (T). RNA also contains four bases; the first three bases are same as in DNA but the fourth one is uracil (U).

13. **Which of the following B group vitamins can be stored in our body?**

- (i) Vitamin B₁
(ii) Vitamin B₂
(iii) Vitamin B₆
(iv) Vitamin B₁₂

Ans. **(iv)**

Explanation: Water soluble vitamins must be supplied regularly in diet because they are readily excreted in urine and cannot be stored (except vitamin B₁₂) in our body.

14. **Which of the following bases is not present in DNA?**

- (i) Adenine
(ii) Thymine

- (iii) Cytosine
- (iv) Uracil

Ans. (iv)

Explanation: Uracil is present in RNA but not in DNA.

15. Three cyclic structures of monosaccharides are given below which of these are anomers.

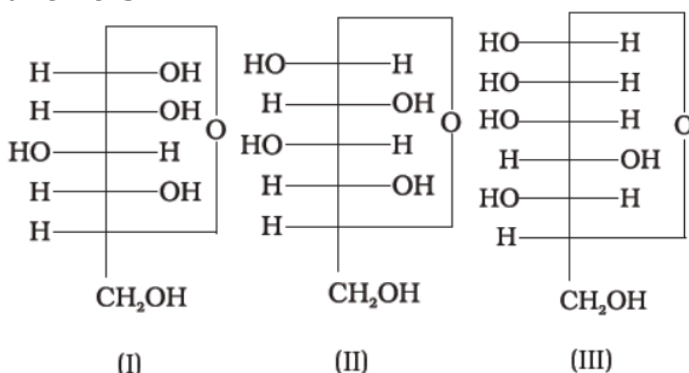

(i) I and II

(ii) II and III

(iii) I and III

(iv) III is anomer of I and II

Ans. (i)

Explanation: This behavior could not be explained by the open chain structure (I) for glucose. It was proposed that one of the —OH groups may add to the —CHO group and form a cyclic hemiacetal structure. It was found that glucose forms a six-membered ring in which —OH at C-5 is involved in ring formation. This explains the absence of —CHO group and also existence of glucose in two forms as shown below.

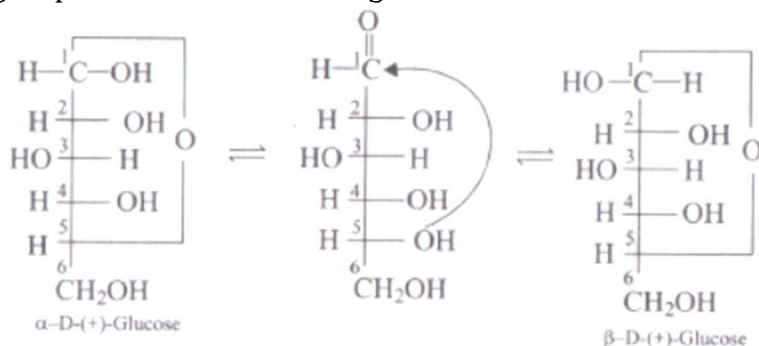

16. Which of the following reactions of glucose can be explained only by its cyclic structure?

(i) Glucose forms pentaacetate.

(ii) Glucose reacts with hydroxylamine to form an oxime.

(iii) Pentaacetate of glucose does not react with hydroxylamine.

(iv) Glucose is oxidised by nitric acid to gluconic acid.

Ans. (iii)

Explanation: The pentaacetate of glucose does not react with hydroxylamine indicating the absence of free —CHO group.

17. **Optical rotations of some compounds along with their structures are given Below. Which of them have D configuration.**

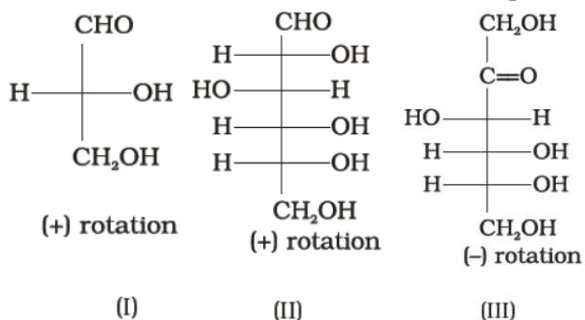

- (i) I, II, III
- (ii) II, III
- (iii) I, II
- (iv) III

Ans. (i)

Explanation: All those compounds which can be chemically correlated to (+) isomer of glyceraldehyde are said to have D-configuration whereas those which can be correlated to (-) isomer of glyceraldehyde are said to have L-configuration.

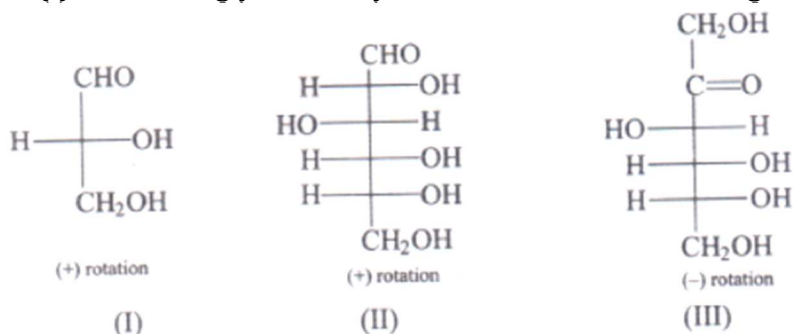

18. **Structure of a disaccharide formed by glucose and fructose is given below. Identify anomeric carbon atoms in monosaccharide units.**

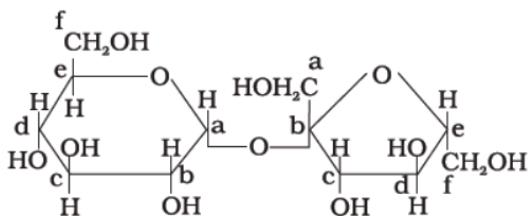

- (i) 'a' carbon of glucose and 'a' carbon of fructose.
- (ii) 'a' carbon of glucose and 'e' carbon of fructose.
- (iii) 'a' carbon of glucose and 'b' carbon of fructose.
- (iv) 'f' carbon of glucose and 'f' carbon of fructose.

Ans. (iii)

Explanation: Two monosaccharides are held together by a glycosidic linkage between C1 of α -glucose and C2 of β -fructose.

19. Three structures are given below in which two glucose units are linked. Which of these linkages between glucose units are between C1 and C4 and which linkages are between C1 and C6?

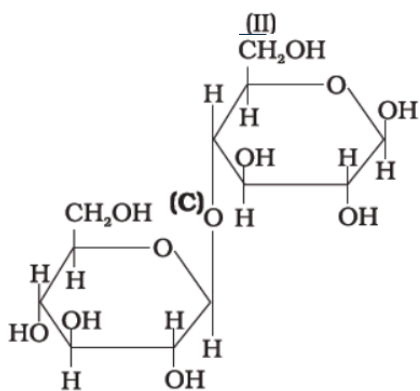
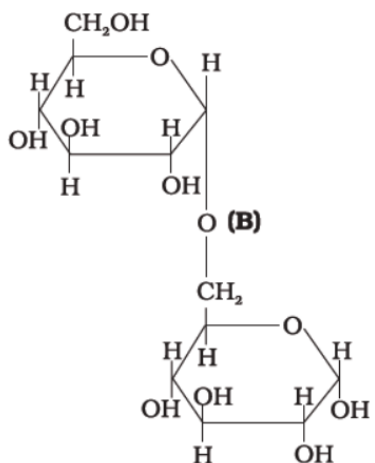
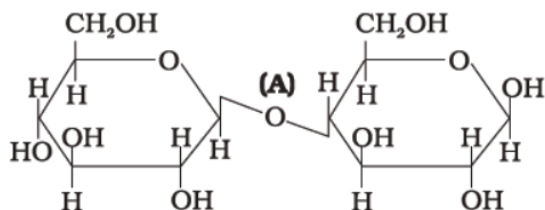

(III)

- (i) (A) is between C1 and C4, (B) and (C) are between C1 and C6
(ii) (A) and (B) are between C1 and C4, (C) is between C1 and C6
(iii) (A) and (C) are between C1 and C4, (B) is between C1 and C6
(iv) (A) and (C) are between C1 and C6, (B) is between C1 and C4

Ans. (iii)

Biomolecules
Multiple Choice Questions (Type-II)

Note: In the following questions two or more options may be correct.

20. Carbohydrates are classified on the basis of their behaviour on hydrolysis and also as reducing or non-reducing sugar. Sucrose is a _____.

- (i) monosaccharide
- (ii) disaccharide
- (iii) reducing sugar
- (iv) non-reducing sugar

Ans. (ii), (iv)

Explanation: One of the common disaccharides is sucrose which on hydrolysis gives equimolar mixture of D-(+)- glucose and D-(-) fructose. These two monosaccharides are held together by a glycosidic linkage between C1 of α -glucose and C2 of β -fructose. Since the reducing groups of glucose and fructose are involved in glycosidic bond formation, sucrose is a non-reducing sugar.

21. Proteins can be classified into two types on the basis of their molecular shape i.e., fibrous proteins and globular proteins. Examples of globular proteins are:

- (i) Insulin
- (ii) Keratin
- (iii) Albumin
- (iv) Myosin

Ans. (i), (iii)

Explanation: Globular proteins: This structure results when the chains of polypeptides coil around to give a spherical shape. These are usually soluble in water. Insulin and albumins are the common examples of globular proteins.

22. Which of the following carbohydrates are branched polymer of glucose?

- (i) Amylose
- (ii) Amylopectin
- (iii) Cellulose
- (iv) Glycogen

Ans. (ii), (iv)

Explanation: Amylopectin is insoluble in water and constitutes about 80-85% of starch. It is a branched chain polymer of α -D-glucose units in which chain is formed by C1-C4 glycosidic linkage whereas branching occurs by C1-C6 glycosidic linkage. **Glycogen:** The carbohydrates are stored in animal body as glycogen. It is also known as animal starch because its structure is similar to amylopectin and is rather more highly branched.

23. Amino acids are classified as acidic, basic or neutral depending upon the relative number of amino and carboxyl groups in their molecule. Which of the following are acidic?

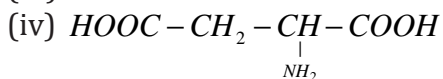
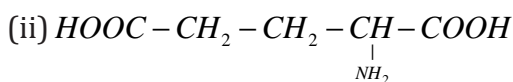
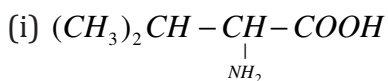

Ans. (ii), (iv)

Explanation: Amino acids are classified as acidic, basic or neutral depending upon the relative number of amino and carboxyl groups in their molecule. Equal number of amino and carboxyl groups makes it neutral; more number of amino than carboxyl groups makes it basic and more carboxyl group as compared to amino groups makes it acidic.

24. Lysine, $H_2N - (CH_2)_4 - \underset{\substack{| \\ NH_2}}{CH} - COOH$ is _____.

- (i) α -Amino acid
- (ii) Basic amino acid
- (iii) Amino acid synthesised in body
- (iv) β -Amino acid

Ans. (i), (ii)

25. Which of the following monosaccharides are present as five membered cyclic structure (furanose structure)?

- (i) Ribose
- (ii) Glucose
- (iii) Fructose
- (iv) Galactose

Ans. (i), (iii)

Explanation: Fructose: It also exists in two cyclic forms which are obtained by the addition of $-OH$ at C5 to the group. The ring, thus formed is a five-membered ring and is named as furanose with analogy to the compound furan. Furan is a five-membered cyclic compound with one oxygen and four carbon atoms.

26. In fibrous proteins, polypeptide chains are held together by _____.

- (i) van der Waals forces
- (ii) disulphide linkage
- (iii) electrostatic forces of attraction
- (iv) hydrogen bonds

Ans. (i), (ii)

Explanation: In fibrous proteins, main forces which stabilize structures of proteins are disulphide linkages and van der Waals.

27. Which of the following are purine bases?

- (i) Guanine
-

-
- (ii) Adenine
 - (iii) Thymine
 - (iv) Uracil

Ans. (i), (ii)

28. Which of the following terms are correct about enzyme?

- (i) Proteins
- (ii) Dinucleotides
- (iii) Nucleic acids
- (iv) Biocatalysts

Ans. (i), (iv)

Explanation: Life is possible due to the coordination of various chemical reaction in living organisms. This occurs with the help of certain biocatalysts called enzymes. Almost all the enzymes are globular Protein.

Biomolecules
Matching Type

Note: Match the items of Column I and Column II in the following questions. More than one option in Column II may match with the items given in Column I.

58. Match the vitamins given in Column I with the deficiency disease they cause given in Column II.

Column I (Vitamins)	Column II (Diseases)
(i) Vitamin A	(a) Pernicious anaemia
(ii) Vitamin B ₁	(b) Increased blood clotting time
(iii) Vitamin B ₁₂	(c) Xerophthalmia
(iv) Vitamin C	(d) Rickets
(v) Vitamin D	(e) Muscular weakness
(vi) Vitamin E	(f) Night blindness
(vii) Vitamin K	(g) Beri Beri (h) Bleeding gums (i) Osteomalacia

Ans. (i)- (c) (ii)- (g)
(iii)- (a) (iv)- (h)
(v)- (d) (vi)- (e)
(vii)- (b)

Explanation:

(i)	Xerophthalmia (hardening of cornea of eye) night blindness.
(ii)	Beri beri (loss of appetite, retarded growth).
(iii)	Pernicious anaemia (RBC deficient in haemoglobin).
(iv)	Scurvy (bleeding gums).
(v)	Rickets (bone deformities in children) and osteomalacia (soft bones and joint pain in adults)
(vi)	Increased fragility of RBCs and muscular weakness.
(vii)	Increased blood clotting time.

59. Match the following enzymes given in Column I with the reactions they catalyse given in Column II.

Column I (Enzymes)	Column II (Reactions)
(i) Invertase	(a) Decomposition of urea into NH ₃ and CO ₂
(ii) Maltase	(b) Conversion of glucose into ethyl alcohol
(iii) Pepsin	(c) Hydrolysis of maltose into glucose
(iv) Urease	(d) Hydrolysis of cane sugar
(v) Zymase	(e) Hydrolysis of proteins into peptides

Ans. (i)- (d) (ii)- (c)
(iii)- (e) (iv)- (a)
(v)- (b)

Biomolecules
Assertion and Reason Type

Note: In the following questions a statement of assertion followed by a statement of reason is given. Choose the correct answer out of the following choices.

- (i) Assertion and reason both are correct statements and reason explains the assertion.
- (ii) Both assertion and reason are wrong statements.
- (iii) Assertion is correct statement and reason is wrong statement.
- (iv) Assertion is wrong statement and reason is correct statement.
- (v) Assertion and reason both are correct statements but reason does not explain assertion.

60. **Assertion:** D (+) – Glucose is dextrorotatory in nature.

Reason: 'D' represents its dextrorotatory nature.

Ans. (iii)

Explanation: Glucose is correctly named as D(+)-glucose. 'D' before the name of glucose represents the configuration whereas '(+)' represents dextrorotatory nature of the molecule. The letters 'D' or 'L' before the name of any compound indicate the relative configuration of a particular stereoisomer.

61. **Assertion:** Vitamin D can be stored in our body.

Reason: Vitamin D is fat soluble vitamin.

Ans. (i)

Explanation: *Fat soluble vitamins* are soluble in fat and oils but insoluble in water. They can be stored in liver and adipose (fat storing) tissues.

62. **Assertion:** β -glycosidic linkage is present in maltose,

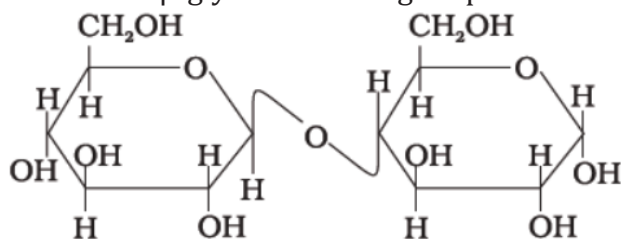

Reason: Maltose is composed of two glucose units in which C-1 of one glucose unit is linked to C-4 of another glucose unit.

Ans. (iv)

Explanation:

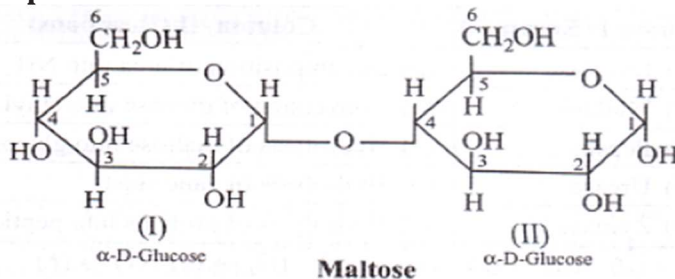

Maltose is composed of two α -D-glucose units in which C1 of one glucose (I) is linked to C4 of another glucose unit (II).

63. **Assertion:** All naturally occurring α -amino acids except glycine are optically active.

Reason: Most naturally occurring amino acids have L-configuration.

Ans. (v)

Explanation: Except glycine, all other naturally occurring α -amino acids are optically active, since the α -carbon atom is asymmetric. These exist both in 'D' and 'L' forms. Most naturally occurring amino acids have L-configuration. L-Amino acids are represented by writing the —NH_2 group on left hand side.

64. **Assertion:** Deoxyribose, $\text{C}_5\text{H}_{10}\text{O}_4$ is not a carbohydrate.

Reason: Carbohydrates are hydrates of carbon so compounds which follow $\text{C}_x(\text{H}_2\text{O})_y$ formula are carbohydrates.

Ans. (ii)

Explanation: Complete hydrolysis of DNA (or RNA) yields a pentose sugar, phosphoric acid and nitrogen containing hetero-cyclic compounds (called bases). In DNA molecules, the sugar moiety is β -D-2- deoxyribose.

65. **Assertion:** Glycine must be taken through diet.

Reason: It is an essential amino acid.

Ans. (ii)

Explanation: The amino acids, which can be synthesised in the body, are known as non-essential amino acids. Glycine is an example of non-essential amino acid.

66. **Assertion:** In presence of enzyme, substrate molecule can be attacked by the reagent effectively.

Reason: Active sites of enzymes hold the substrate molecule in a suitable position.

Ans. (i)

Explanation: In presence of enzyme, substrate molecule can be attacked by the reagent effectively because active sites of enzymes hold the substrate molecule in a suitable position.

Biomolecules
Short Answer Type

29. Name the sugar present in milk. How many monosaccharide units are present in it? What are such oligosaccharides called?

Ans. Lactose is commonly known as milk sugar since this disaccharide is found in milk. It is composed of β -D-galactose and β -D-glucose. The linkage is between C1 of galactose and C4 of glucose.

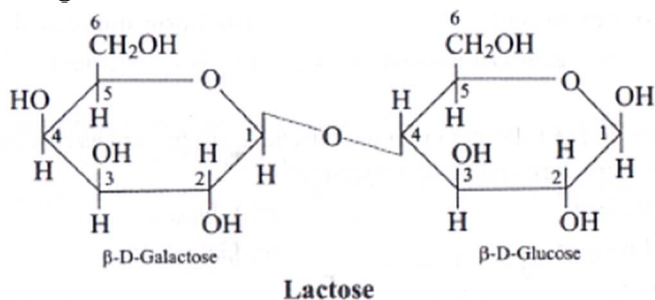

30. How do you explain the presence of all the six carbon atoms in glucose in a straight chain?

Ans. On prolonged heating with HI, glucose gives *n*-hexane.

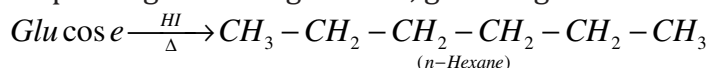

31. In nucleoside a base is attached at 1' position of sugar moiety. Nucleotide is formed by linking of phosphoric acid unit to the sugar unit of nucleoside. At which position of sugar unit is the phosphoric acid linked in a nucleoside to give a nucleotide?

Ans. Phosphoric acid is linked at 5'-position of sugar moiety of nucleoside to give a nucleotide.

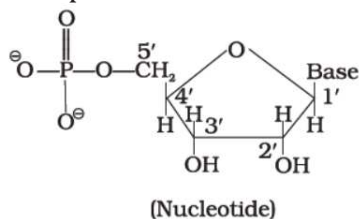

32. Name the linkage connecting monosaccharide units in polysaccharides.

Ans. Glycosidic linkage.

33. Under what conditions glucose is converted to gluconic and saccharic acid?

Ans. Glucose is converted to gluconic acid by bromine water and to saccharic acid by conc. HNO₃.

34. Monosaccharides contain carbonyl group hence are classified, as aldose or ketose. The number of carbon atoms present in the monosaccharide molecule are also considered for classification. In which class of monosaccharide will you place fructose?

Ans. Fructose is an important ketohexose. It is obtained along with glucose by the hydrolysis of disaccharide, sucrose. Fructose also has the molecular formula $C_6H_{12}O_6$ and on the basis of its reactions it was found to contain a ketonic functional group at carbon number 2 and six carbons in straight chain as in the case of glucose.

35. The letters 'D' or 'L' before the name of a stereoisomer of a compound indicate the correlation of configuration of that particular stereoisomer. This refers to their relation with one of the isomers of glyceraldehyde. Predict whether the following compound has 'D' or 'L' configuration.

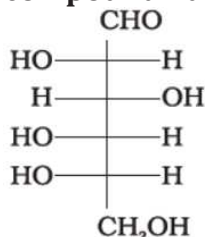

Ans. The letters 'D' or 'L' before the name of any compound indicate the relative configuration of a particular stereoisomer. This refers to their relation with a particular isomer of glyceraldehydes.

D' before the name of glucose represents the configuration whereas '(+)' represents dextrorotatory nature of the molecule. It may be remembered that 'D' and 'L' have no relation with the optical activity of the compound. For assigning the configuration of monosaccharides, it is the lowest asymmetric carbon atom which is compared. The given compound has L-configuration.

36. Aldopentoses named as ribose and 2-deoxyribose are found in nucleic acids. What is their relative configuration?

Ans. configuration assigned is O. Thus, robose is β -D-ribose Deoxyribose is β -D-2-deoxyribose.

37. Which sugar is called invert sugar? Why is it called so?

Ans. Sucrose is dextrorotatory but after hydrolysis gives dextrorotatory glucose and laevorotatory fructose. Since the laevorotation of fructose (-92.4°) is more than dextrorotation of glucose ($+52.5^\circ$), the mixture is laevorotatory. Thus, hydrolysis of sucrose brings about a change in the sign of rotation, from dextro (+) to laevo (-) and the product is named as invert sugar.

38. Amino acids can be classified as α -, β -, γ -, δ - and so on depending upon the relative position of amino group with respect to carboxyl group. Which type of amino acids form polypeptide chain in proteins?

Ans. α -amino acids form polypeptide chain in proteins.

39. α -Helix is a secondary structure of proteins formed by twisting of polypeptide chain into right handed screw like structures. Which type of interactions are responsible for making the α -helix structure stable?

Ans. In α -helix, apolypeptide chain is stabilized by the formation of hydrogen bonds between —NH— group of amino acids in one turn with the >C—O groups of amino acids belonging to adjacent turn.

40. Some enzymes are named after the reaction, where they are used. What name is given to the class of enzymes which catalyse the oxidation of one substrate with simultaneous reduction of another substrate.

Ans. Oxidoreductase is class of enzymes which catalyse the oxidation of one substrate with simultaneous reduction of another substrate.

41. During curdling of milk, what happens to sugar present in it?

Ans. When milk is curdeled, its sugar get oxidize to form lactic acid.

42. How do you explain the presence of five —OH groups in glucose molecule?

Ans. Acetylation of glucose with acetic anhydride gives glucose pentaacetate which confirms the presence of five —OH groups. Since it exists as a stable compound, five —OH groups should be attached to different carbon atoms.

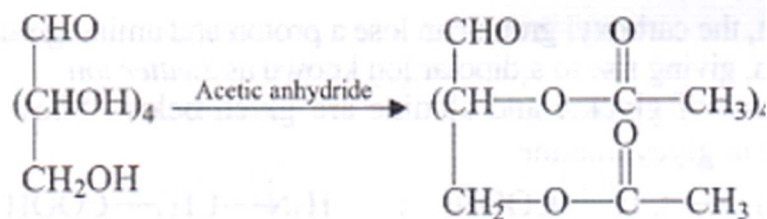

43. Why does compound (A) given below not form an oxime?

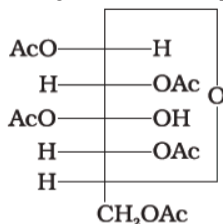

(A)

Ans. Glucose pentaacetate (structure A) doesn't have a free —OH group at C1 and so can't be converted to the open chain form to give —CHO group and hence doesn't form the oxime.

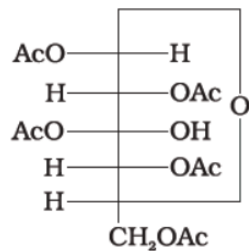

(Structure A)

44. Why must vitamin C be supplied regularly in diet?

Ans. Vitamin C are soluble in water. Water soluble vitamins must be supplied regularly in diet because they are readily excreted in urine and cannot be stored in our body.

45. Sucrose is dextrorotatory but the mixture obtained after hydrolysis is laevorotatory. Explain.

Ans. Sucrose is dextrorotatory but after hydrolysis gives dextrorotatory glucose and laevorotatory fructose. Since the laevorotation of fructose (-92.4°) is more than dextrorotation of glucose ($+52.5^{\circ}$), the mixture is laevorotatory.

46. Amino acids behave like salts rather than simple amines or carboxylic acids. Explain.

Ans. Amino acids behave like salts rather than simple amines or carboxylic acids. This behaviour is due to the presence of both acidic (carboxyl group) and basic (amino group) groups in the same molecule. In aqueous solution, the carboxyl group can lose a proton and amino group can accept a proton, giving rise to a dipolar ion known as *zwitter ion*.

47. Structures of glycine and alanine are given below. Show the peptide linkage in glycylalanine.

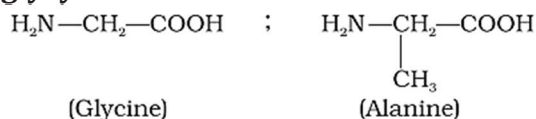

Ans. In glycylalanine, carboxyl group of glycine combines with the amino group of alanine.

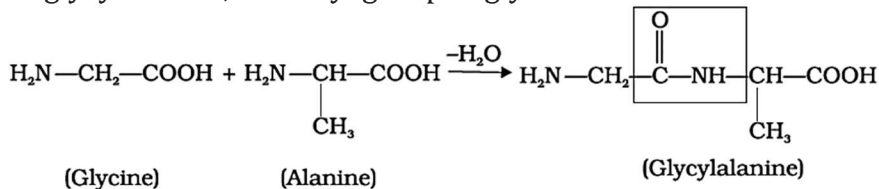

48. Protein found in a biological system with a unique three-dimensional structure and biological activity is called a native protein. When a protein in its native form, is subjected to a physical change like change in temperature or a chemical change like, change in pH, denaturation of protein takes place. Explain the cause.

Ans. Protein found in a biological system with a unique three-dimensional structure and biological activity is called a native protein. When a protein in its native form, is subjected to physical change like change in temperature or chemical change like change in pH, the hydrogen bonds are disturbed. Due to this, Globules unfold and helix get uncoiled and protein loses its biological activity. This is called denaturation of protein.

49. Activation energy for the acid catalysed hydrolysis of sucrose is 6.22 kJ mol^{-1} , while the activation energy is only 2.15 kJ mol^{-1} when hydrolysis is catalysed by the enzyme sucrase. Explain.

Ans. Enzymes are needed only in small quantities for the progress of a reaction. Similar to the action of chemical catalysts, enzymes are said to reduce the magnitude of activation

energy. For example, activation energy for acid hydrolysis of sucrose is 6.22 kJ mol^{-1} , while the activation energy is only 2.15 kJ mol^{-1} when hydrolysed by the enzyme, sucrase.

50. How do you explain the presence of an aldehydic group in a glucose molecule?

Ans. Glucose gets oxidised to six carbon carboxylic acid (gluconic acid) on reaction with a mild oxidising agent like bromine water. This indicates that the carbonyl group is present as an aldehydic group.

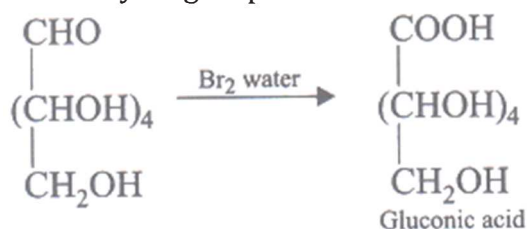

51. Which moieties of nucleosides are involved in the formation of phosphodiester linkages present in dinucleotides? What does the word diester in the name of linkage indicate? Which acid is involved in the formation of this linkage?

Ans. When nucleoside is linked to phosphoric acid at 5-position of sugar moiety, it forms a nucleotide. Nucleotides are joined together by phosphodiester link between 5' and 3' carbon atoms of the pentose sugar.

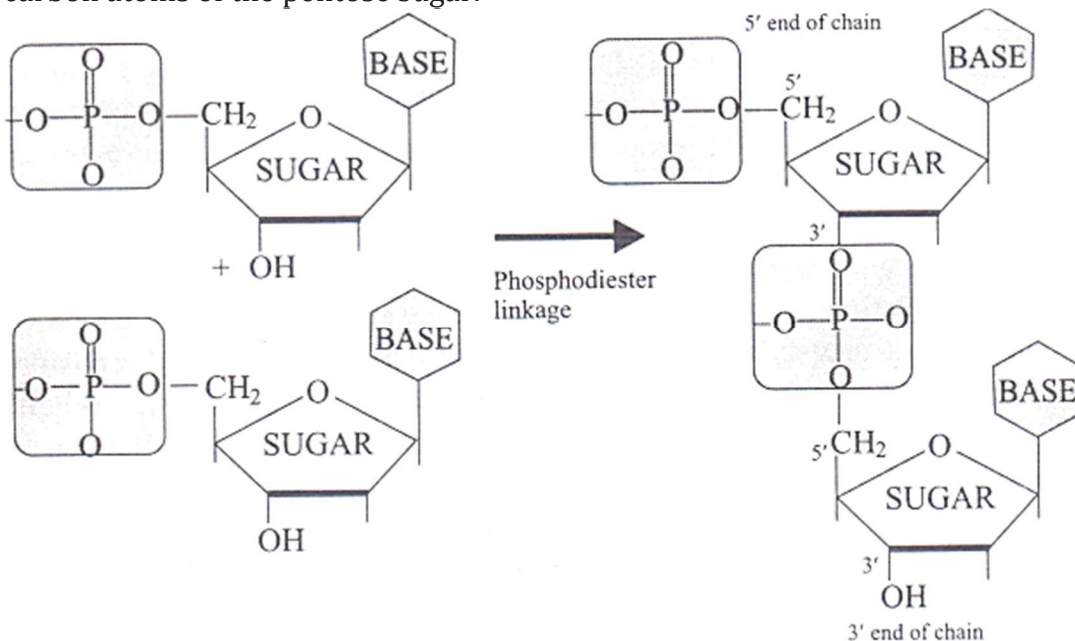

Phosphoric acid is involved in the formation of this linkage.

52. What are glycosidic linkages? In which type of biomolecules are they present?

Ans. The two monosaccharides are joined together by an oxide linkage formed by the loss of a water molecule. Such a linkage between two monosaccharides are held together by a glycosidic linkage between C1 of α -glucose and C2 of β -fructose. Since the reducing

groups of glucose and fructose are involved in glycosidic bond formation, between two monosaccharide units through oxygen atom is called glycosidic linkage.

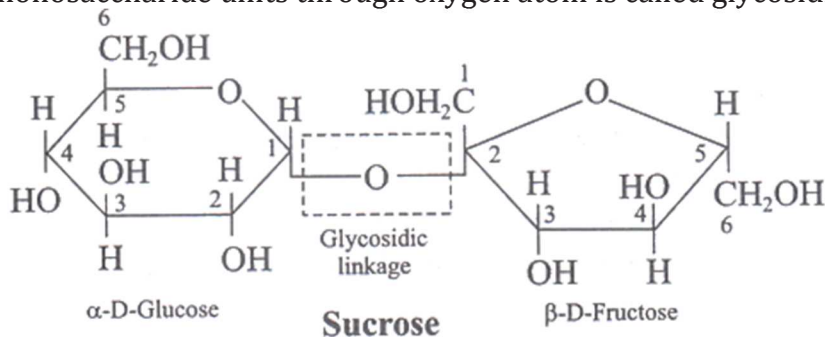

53. Which monosaccharide units are present in starch, cellulose and glucose and which linkages link these units?

Ans. In starch and glycogen, glycosidic α -linkage is present. Cellulose is a straight chain polysaccharide composed only of β -D-glucose units which are joined by glycosidic linkage between C1 of one glucose unit and C4 of the next glucose unit.

54. How do enzymes help a substrate to be attacked by the reagent effectively?

Ans. Enzymes are highly specific. They react with substrate molecule and form intermediate complex. They reduce the magnitude of activation energy.

55. Describe the term D- and L- configuration used for amino acids with examples.

Ans. Amino acid exists both in 'D' and 'L' forms. Most naturally occurring amino acids have L-configuration. L-Amino acids are represented by writing the —NH_2 group on left hand side and D-amino acids are represented by writing the —NH_2 group on right hand side.

56. How will you distinguish 1° and 2° hydroxyl groups present in glucose? Explain with reactions.

Ans. On oxidation with nitric acid, glucose as well as gluconic acid both yield a dicarboxylic acid, saccharic acid. This indicates the presence of a primary alcoholic (—OH) group in glucose.

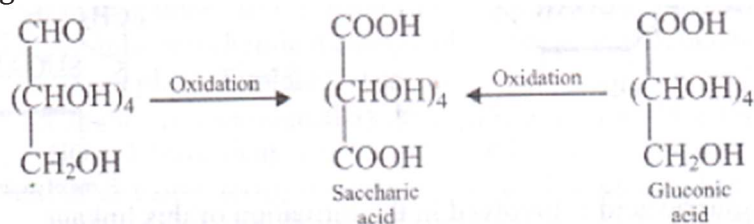

Acetylation of glucose with acetic anhydride gives glucose pentaacetate which confirms the presence of five —OH groups. Since it exists as a stable compound, five —OH groups should be attached to different carbon atoms.

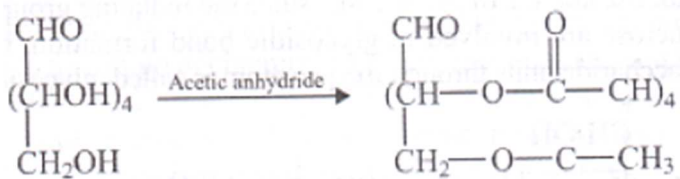

57. **Coagulation of egg white on boiling is an example of denaturation of protein. Explain it in terms of structural changes.**

Ans. During denaturation 2 and 3 structures are destroyed but 1^o structure remains intact. The coagulation of egg white on boiling is a common example of denaturation.

Biomolecules
Long Answer Type

67. Write the reactions of D-glucose which can't be explained by its open-chain structure. How can cyclic structure of glucose explain these reactions?

Ans. Following reactions and facts could not be explained by open chain structure of glucose.

- Despite having the aldehyde group, glucose does not give 2,4-DNP test, Schiff's test and it does not form the hydrogensulphite addition product with NaHSO_3 .
- The pentaacetate of glucose does not react with hydroxylamine indicating the absence of free $-\text{CHO}$ group.

It was proposed that one of the $-\text{OH}$ groups may add to the $-\text{CHO}$ group and form a cyclic hemiacetal structure. It was found that glucose forms a six-membered ring in which $-\text{OH}$ at C-5 is involved in ring formation.

68. On the basis of which evidences D-glucose was assigned the following structure?

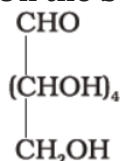

Ans. Glucose is an aldohexose and is also known as dextrose. It is the monomer of many of the larger carbohydrates, namely starch, cellulose. It is probably the most abundant organic compound on earth. It was assigned the structure given below on the basis of the following evidences:

(i) Its molecular formula was found to be $\text{C}_6\text{H}_{12}\text{O}_6$.

(ii) On prolonged heating with HI, it forms n-hexane, suggesting that all the six carbon atoms are linked in a straight chain. Glucose reacts with hydroxylamine to form an oxime and adds a molecule of hydrogen cyanide to give cyanohydrins. These reactions confirm the presence of a carbonyl group ($>\text{C}=\text{O}$) in glucose. Glucose gets oxidised to six carbon carboxylic acid (gluconic acid) on reaction with a mild oxidising agent like bromine water. This indicates that the carbonyl group is present as an aldehydic group.

69. Carbohydrates are essential for life in both plants and animals. Name the carbohydrates that are used as storage molecules in plants and animals, also name the carbohydrate which is present in wood or in the fibre of cotton cloth.

Ans. Starch is the main storage polysaccharide of plants. It is the most important dietary source for human beings. High content of starch is found in cereals. Cellulose occurs exclusively in plants and it is the most abundant organic substance in plant kingdom. Cell wall of bacteria and plants is made up of cellulose. We build furniture, etc. from cellulose in the form of wood and clothe ourselves with cellulose in the form of cotton fibre.

70. Explain the terms primary and secondary structure of proteins. What is the difference between α -helix and β -pleated sheet structure of proteins?

Ans. Primary structure of proteins: Proteins may have one or more polypeptide chains. Each polypeptide in a protein has amino acids linked with each other in a specific sequence

and it is this sequence of amino acids that is said to be the primary structure of that protein. Any change in this primary structure i.e., the sequence of amino acids creates a different protein.

Secondary Structure of Proteins: The secondary structure of protein refers to the shape in which a long polypeptide chain. The secondary can exist. They are found to exist in two different types of structures viz. α -helix and β -pleated sheet structure. These structures arise due to the regular folding of the backbone of the polypeptide chain due to hydrogen bonding between carbonyl group and —NH— groups of the peptide bond. α -Helix is one of the most common ways in which a polypeptide chain forms all possible hydrogen bonds by twisting into a right handed screw (helix) with the carbonyl and —NH group of each amino acid residue hydrogen bonded to the ($>\text{C}=\text{O}$) of an adjacent turn of the helix. In β -structure all peptide chains are stretched out to nearly maximum extension and then laid side by side which are held together by intermolecular hydrogen bonds.

71. Write the structures of fragments produced on complete hydrolysis of DNA. How are they linked in DNA molecule? Draw a diagram to show pairing of nucleotide bases in double helix of DNA.

Ans. Complete hydrolysis of DNA (or RNA) yields a pentose sugar, phosphoric acid and nitrogen containing heterocyclic compounds (called bases). In DNA molecules, the sugar moiety is β -D-2-deoxyribose.

Two nucleic acid chains are wound about each other and held together by hydrogen bonds between pairs of bases. The two strands are complementary to each other because the hydrogen bonds are formed between specific pairs of bases.

